



## Perching behaviour in chickens and its relation to spatial ability

Anette Wichman<sup>a</sup>, Matti Heikkilä<sup>b</sup>, Anna Valros<sup>b</sup>,  
Björn Forkman<sup>c</sup>, Linda J. Keeling<sup>a,\*</sup>

<sup>a</sup> *Department of Animal Environment and Health, Swedish University of Agricultural Sciences, Skara, Sweden*

<sup>b</sup> *Research Centre for Animal Welfare, Department of Clinical Veterinary Science, University of Helsinki, Finland*

<sup>c</sup> *Department of Animal Science and Animal Health, The Royal Veterinary and Agricultural University, Copenhagen, Denmark*

Accepted 22 May 2006

Available online 7 July 2006

---

### Abstract

The early rearing environment plays an important role in the development of many behaviour patterns and it has been shown that an early use of perches by chicks improves their later three-dimensional spatial ability. But even if birds are reared in the same environment, there can be large individual differences in how well birds use the perches. Therefore, the aim of this study was to explore the link between the development of perching in chicks and their spatial ability.

Ninety-day-old LSL chicks were housed in rearing pens ( $n = 18$ ). From day 1 they had access to perches (20 and 40 cm high). At 18 weeks of age the birds were moved to layer pens which were bigger and had more perches at different heights ( $n = 5$ ). The study included observations of perching behaviour of the birds in their home pens and two spatial tests. The first perching observations of the chicks were carried out in the rearing pens from 5 days until 6 weeks of age and the second during the first 5 days in the layer pens, when the birds were presumably adapting to these new pens. The two spatial tests were firstly, a detour test when the chicks were 4 days old and, secondly, a radial eight armed maze test when the birds were 15–16 weeks old. In addition to the spatial tests a TI (tonic immobility) test and a runway test were carried out to allow comparisons of the chicks' spatial performance with their fearfulness and sociality.

There was no evidence from this study that the two-dimensional spatial skill of a newly hatched chick influenced how it learnt to perch and so no support for there being an early link between a chicks spatial ability and perching behaviour. But spatial skill as a pullet did seem to influence perch use in a new and

---

\* Corresponding author. Tel.: +46 18 671622; fax: +46 18 309565.

E-mail address: [Linda.Keeling@hnh.slu.se](mailto:Linda.Keeling@hnh.slu.se) (L.J. Keeling).

complex situation, suggesting that spatial skill in a two-dimensional test is related to performance in a three-dimensional spatial test situation.

© 2006 Elsevier B.V. All rights reserved.

*Keywords:* Chickens; Perching; Rearing; Spatial ability

---

## 1. Introduction

More and more laying hens are housed in non-cage systems, such as aviaries, to give possibilities to perform a wider range of different behaviour patterns than in cages and thus promote hen welfare. But an aviary system is constructed on more than one level and to be able to reach resources such as food, water, nest boxes and sometimes even litter, and so reap these potential welfare benefits, it is essential that the hens can use the three-dimensional space in a good way. This puts higher demands on them and it seems not all birds respond in such a way that they are able to make full use of these benefits (Gunnarsson et al., 1999).

Night perching (roosting) has evolved in the hens natural habitat as a behaviour to avoid predation during the night. Being so essential for survival, all chicks living under natural conditions need to learn this. Domestic hens kept under commercial conditions are usually still highly motivated to perch, even though they are not threatened by any predators. Studies have shown that hens are willing to work to get access to perches at night (Olsson and Keeling, 2002) and are frustrated when access is blocked (Olsson and Keeling, 2000). Perches are also used during the daytime for resting, preening and as a retreat for lower ranking birds to avoid aggressive encounters (Cordiner and Savory, 2001). Birds with access to perches tend to be less fearful than birds in systems without perches (Brake et al., 1994) and it has been suggested that perching gives the hen a feeling of security (Keeling, 1997). Studies have shown that early access to perches results in hens having a better later use of three-dimensional space. For example, chicks provided with perches before 8 weeks of age lay more of their eggs in elevated nest boxes compared to hens that had been reared without perches, which to a higher degree laid their eggs on the floor (Appleby et al., 1988). This has been confirmed under commercial conditions, as has the fact that hens reared with perches have a lower incidence of cannibalism (Gunnarsson et al., 1999). Yngvesson (2002) found that hens that had been reared with access to perches were better at avoiding a simulated cannibalistic attack by jumping up on a perch than those reared without perches. A more flexible use of the three-dimensional space is believed to be a consequence of the interaction between development of behaviour and the development of the brain. During the chick's first 60 days there is a maturation of the synapses in the brain and chicks are more susceptible to learn certain behaviour (Rogers, 1995, p. 5). The hippocampus seems to be the part of the brain where most processing of spatial information takes place and in experiments where rats had their hippocampus lesioned spatial orientation was impaired. Lesioned rats performed poorly in a radial maze and needed more choices to find the right arms compared to control animals, but no impairment was found in the rat's performance in other types of tasks (Sherry and Healy, 1998, p. 141). Findings are similar in birds. In a series of experiments comparing hoarding (storing food in several different places) versus non-hoarding species, the general finding is that hoarding species have better spatial memory and a larger relative hippocampus (e.g. Healy et al., 1994; Kamil et al., 1994). Additional support for the suggestion that perching ability is related to spatial ability is that in broods of chicks kept in semi natural environments there is a peak in perching at day 10. This change in behaviour coincides with a shift towards using the right hemisphere, which is the hemisphere dominantly used for spatial

processing (Workman and Andrew, 1989). Even when animals are reared under the same conditions they do not necessarily develop and behave in the same way. For example, there can be a large individual variation between chicks in how much they use perches, even if all have had the same access (Yngvesson, 2002). Also perch use can vary between flocks of adult birds of the same strain reared in the same environment (Appleby and Duncan, 1989). This begs the question as to what degree chicks hatch with a good spatial ability, and therefore learn to perch well early in life and what degree of spatial ability is achieved by the actual use of the perches and so less connected to the initial learning of perching.

The question this experiment aimed to investigate was:

- is there a relationship between a birds perching behaviour and its spatial ability as measured in a two-dimensional spatial task?

and if we found a relation between perching and spatial ability:

- does a chick start to perch early because it is hatched with a good spatial ability, so-called innate spatial ability?
- or does the spatial ability develop mostly through an early and frequent use of perches, so-called acquired spatial ability?

Of course these two alternatives do not need to be mutually exclusive, and indeed they most probably interact as the chick matures, but with the experimental setup in this study where we monitored perching behaviour and performance in tests of spatial skill at different ages, we hoped to make a first attempt to tease apart these different putative effects.

In this study we define spatial ability as the ability to orient in the environment. To assess spatial ability we selected a detour test for the chicks and the radial maze for the pullets. The reason for choosing tests that investigated two-dimensional spatial ability instead of three-dimensional spatial ability was to be able to exclude the confounding factors of physical ability and coordination which would be affected by how much birds used the perches in their home pen. Detour tests have been used previously on very young chicks (Scholes and Wheaton, 1966) and it has been shown that they can solve a detour problem in a single trial (Regolin et al., 1995a). Both these aspects were important because we wanted to be able to test spatial skills in chicks before they start learning to perch, which could be as early as 1 week of age. The radial maze has been used to test spatial learning and memory in different bird species (Wilkie et al., 1981; Kamil et al., 1994; Lipp et al., 2001; Zimmerman et al., 2003).

In the current study our aim was to test hens' ability to go around an object and remember where they had already been, which would show their ability to solve spatial problems. However, performance in a test situation has been shown to be influenced by fearfulness (Regolin et al., 1995b) and sociality (Jones et al., 1999). For this reason a tonic immobility (TI) test and a runway test, which are frequently used tests to investigate these variables, were performed on all individuals.

To make this study as applicable as possible to the commercial situation, observations of perching behaviour were also made at the age when pullets are usually moved from the rearing to the layer house. At this time it is crucial that birds are able to adapt to the new environment; learn to use the perches arranged differently from in the rearing pen, find food and water and to use the nest boxes. In an attempt to simulate this in our experimental situation, our birds were moved to new more complex pens with larger group sizes.

## 2. Material and methods

### 2.1. Animals and housing

Ninety Lohman Selected Leghorn (LSL) commercial chicks of a laying strain were purchased from a hatching company and arrived at the experimental farm as day old.

#### 2.1.1. Rearing pens

On arrival the chicks were randomly placed in groups of 5 in 18 pens. Each pen was 1.4 m × 2.0 m with wood shavings on the floor, two perches each 1.4 m long, at heights 20 and 40 cm, a heating lamp and ad lib access to food and water. As the first perching observations were part of another study investigating how environmental enrichment affected perch use in chicks, three different treatments, two with environmental enrichment and one control were used. As treatments were balanced, effects of the enrichment will not be discussed in this paper, but see Heikkilä et al. (2006) for a full description.

#### 2.1.2. Laying pens

When 18 weeks old the 87 remaining chickens (three had died during the first 5 weeks) were moved to five laying pens (Fig. 1). Birds were allocated to the laying pens so that each of the five hens that had been together in a rearing pen was placed in a different laying pen. In this way, all hens in the laying pen were unfamiliar with the other 17 (or 16) hens placed there at the same time. Hens therefore experienced both a new environment as well as being put together with unfamiliar hens.

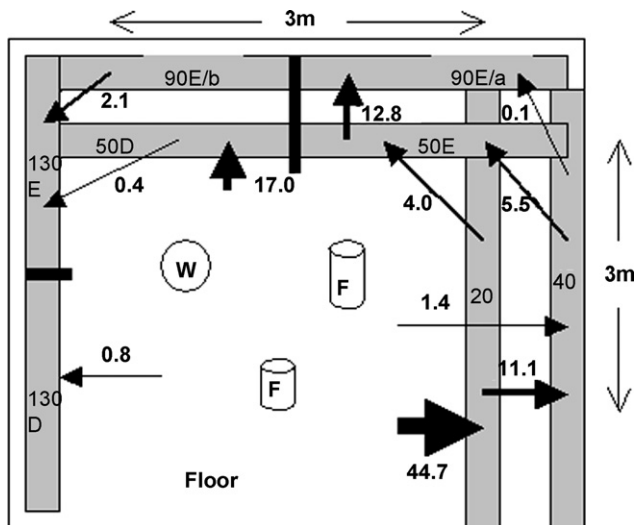

Fig. 1. Schematic figure of a laying pen showing proportions of jumps between different perch categories. The grey bars represent perches and the number inserted in each bar indicates the perch height and whether it was considered as difficult (D) or easy (E) access. To distinguish the two halves of the 90 perch they have been labelled 90E/a, which is the part above the 50E perch, and 90E/b, which is the half above the 50D perch. The black bar crossing the 50, 90 and 130 perches represents the netting preventing the birds walking along the perch. The arrows indicate the direction and the number indicates the percentage of jumps. W, water automat; F, feeder.

Each laying pen had wood shavings on the floor and perches at five different heights along three of the pen walls arranged in such a way so that they could be reached either by jumping from other perches (easy access, E) or by jumping from the floor (difficult access, D). Each perch was 3 m long, thus giving a space allowance of 16 cm/bird, which was sufficient for all hens to be on the same perch at the same time. This resulted in eight different perch height/categories; 20, 40, 50E, 50D, 90E/a, 90E/b, 130E and 130D and a possibility of 15 different combinations of jumps between the perches so differences in flexibility of perch use by birds could be identified.

## 2.2. Identification

At day 4, chicks were marked with numbered plastic tags in five different colours for individual identification. The tags were attached with a plastic string through the skin of the neck. At 18 weeks, in combination with the move to the laying pens, leg rings in different colour combinations were put on the hens. The tags and rings made it possible to individually identify the birds during direct observations by a person standing outside the pen.

## 2.3. Perching observations

### 2.3.1. Rearing pens

From the day the chicks were 5 days old until they were 42 days old, 12 scans per day of perching behaviour were carried out where it was recorded whether a chick was perching or not and, if so, whether it was perching on the low or the high perch. From days 5 to 21, observations were carried out every day, from days 22 to 35 observations were carried out five times per week and from days 36 to 42 observations were carried out three times per week. In total this resulted in 360 scans. The light schedule was a 8:16 h light:dark cycle and the observations were distributed over the day with two scans before lights on, two immediately after lights on, two in the middle of the day, two in the afternoon, two immediately after the lights out and the last two scans after the lights had been off for 2 h. For more detail, see [Heikkilä et al. \(2006\)](#). When all observations of the chicks in the rearing pens were completed, day length was increased by 10 min per day until a 12:12 h light:dark cycle had been reached.

### 2.3.2. Laying pens

Lights in the room with the laying pens came on at 06.00 h and went out at 18.00 h. Observations on daytime perching were carried out during the first five consecutive days between 8.15 and 10.00 h, 12.00 and 13.45 h and 16.00 and 17.45 h and night roosting observations were carried out during the first 10 consecutive nights.

Continuous and scan observations were used for the daytime observations, during which each pen was observed for 5 min to record movements from the floor up onto a perch and upward jumps from one perch to another. Immediately after the period of continuous observations, a scan observation was made to determine the identity and location of all birds on a perch. The next pen was then observed and so on, until all pens had been observed three times within each specified time period. Some extra scans were carried out during the first observation period when the birds had just been released into the pens to allow for a more detailed analysis of initial perching behaviour. In total each pen was continuously recorded for a total of 5 h and scanned 69 times. The first 5 nights perching observations were carried out after the lights went out without any gradual decrease in intensity, whereas for nights 6–10 a 15-min twilight period was used as a cue

for darkness. The night perching observations were always conducted after a 15-min period of complete darkness.

## 2.4. Spatial tests

### 2.4.1. Detour test

The detour test was performed when the chicks were 4 days old. All five chicks from one pen were taken out and put into the companion compartment of the test arena (Fig. 2). After 3 min one of the chicks was moved to the start area of the arena. After release, the time for the chick to move out of the start area and pass the goal line was recorded. If they had not managed to do this within 10 min, the test session was ended, the test chick put back with the companion chicks and a new test chick taken until all five chicks had been tested. Three observers performed tests simultaneously so that all the chicks could be tested during the same day.

### 2.4.2. Radial eight armed maze test

This test was carried out when the birds were 15–16 weeks of age, i.e. after they had started to use perches in their home pen. During the test, each bird's ability to navigate and find mealworms in a radial maze was investigated. The arena consisted of eight arms arranged in a circle (Fig. 3). In the centre of the arena there was a circular start-cage made of wire netting and at the end of each arm was a blue bowl containing one mealworm. To solve the test correctly a bird entered each arm once and ate the mealworm in the bowl. If a bird entered an arm where she had already been and eaten the mealworm an error was recorded. It was not possible to see the bottom of the bowl from a distance so to be able to see whether or not it contained a mealworm, the bird had to approach quite closely and look down into the bowl. From when the start-cage was raised, we observed the time to eat the first mealworm, the number of arms entered until all eight mealworms were eaten and the time to eat all mealworms. If the bird did not complete the test in the maximum time allowed (20 min), the number of mealworms eaten was recorded. The walls of the arena were 50 cm high and the roof made of netting, so it was possible for the birds to look out of the arena to get cues from the interior of the test room to help them orientate.

In order to accustom the birds to the bowls and for them to learn that they contained attractive food, the bowls were placed in the home pen for 30 min the evening before the test. Initially the

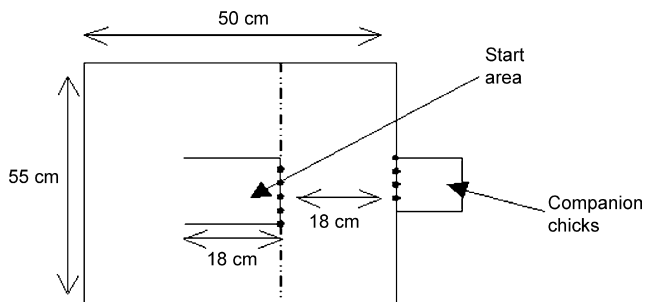

Fig. 2. Detour arena. The arena was made of masonite and measured 50 cm × 55 cm × 25 cm (width × depth × height). The start area where the test chick was placed measured 18 cm × 15 cm × 25 cm whereas the compartment for the companion chicks measured 15 cm × 15 cm × 12 cm. The part of the test pen facing the companion chicks and the wall of the companion box that faced the test arena were made of wire mesh 0.5 cm × 0.5 cm so companion chicks and test chick were clearly visible to each other.

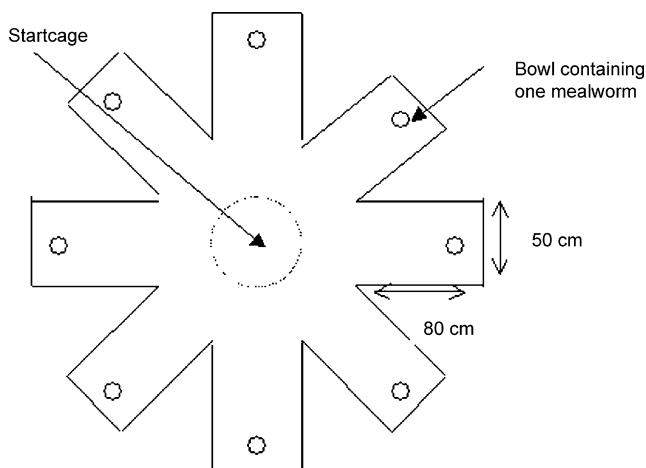

Fig. 3. Schematic diagram of the radial eight armed maze.

bowls contained sunflower seeds, but before they were removed mealworms were introduced and notes were taken to ensure that each hen had eaten at least one mealworm. The five birds from each pen were then released together into the test arena for 30 min habituation. The next day the group was released again in the arena for 30 min before testing started. During these group training sessions in the arena the bowls contained sunflower seeds. After this group training, birds were returned to their home pen and were once again offered mealworms in the bowls. The actual testing of the birds took place between 09.00 and 14.00 h each day and the testing period lasted for 11 days with two pens (10 birds) tested individually each day.

### 2.5. Tonic immobility

When the birds were 8 weeks old a tonic immobility (TI) test was carried out. From each pen three of the chicks were tested on day 1 and two chicks on day 2. The time at which the test was carried out was the same for both testing days. The chicks to be tested that day were caught and placed in a crate within the pen, the other chicks remained free. At the start of the TI test, the chick was gently held down in a V-shaped cradle (placed within the pen) for 10 s, after which the grip on the chick was slowly relaxed. If the chick remained immobile after being released, the time immobile was recorded. If it exceeded 600 s the test was stopped. If the bird had not acquired an immobile state after three induction attempts, the test was considered completed and the chick returned to its home pen.

### 2.6. Runway test

The social reinstatement behaviour of the birds was evaluated using a runway test. The runway was 350 cm × 50 cm × 50 cm (length × width × height) with sides made of masonite, roof made of net and the floor covered with wood-shavings. At one end of the runway there was a start box (40 cm × 40 cm × 40 cm), with a sliding door made of net, and at the other end was the companion box (50 cm × 50 cm × 50 cm). The side of the companion box facing the runway was made of netting so that the bird in the start box could see the birds in the companion box. The middle of the runway and the position 50 cm from the companion box were marked with a stripe

of black tape on the floor. The area within 50 cm of the companion box was referred to as the goal zone.

Testing was carried out during three consecutive days when the birds were 14 weeks old, i.e. just before the radial maze test. All five birds from one home pen were tested on the same occasion. The test started with them being put together into the companion box in the runway and left to acclimatize for 2 min. One bird was then taken out and put into the start box. After 30 s the door was raised and the bird allowed to move freely in the runway for 10 min. During this time, notes were taken of the time it took the bird to leave the start box, the time to reach halfway, the time to reach the goal zone, the accumulated time within the goal zone and the number of entries into the goal zone. When 10 min had passed, the test bird was put back in the companion box and a new bird was taken out and put in the start box, and so forth until all five birds had been tested.

### 2.7. Statistical analysis

All statistical analyses were carried out using Minitab (release 14). Mann–Whitney's test was used to analyse the comparison of whether how high birds roosted in the layer pen depended on whether there was a dimmer effect on the light or not. A Kruskal–Wallis test was used to investigate the effect of pen on the use of perches during daytime scan observations. To investigate the relationship between several parameters within and between tests and observations Principal Component Analyses (PCA) were used. The PCA analyses were carried out based on the Spearman correlation, but the second one was non-standard and had to consider the problem that the number of observations were different for the different variables.

## 3. Results

### 3.1. Early perch use in rearing pens

Data on perching behaviour on the high and low perch were combined. The mean day the chicks were first seen on a perch was  $15.6 \pm 0.49$  (mean  $\pm$  S.E.) days of age. The first chick seen on a perch was 8 days old and all but one chick had begun using the perches before the end of the observation period at 6 weeks old. Frequency of perch use by an individual chick is presented as a percentage time perching calculated from the scans after the date when that individual was first observed on a perch. In this way time to start perching could be separated from amount of time perching. The average percentage time perching was  $8.9 \pm 0.51$ , but ranged from as high as 25% to a low of 0% since one chick was never seen perching (Heikkilä et al., 2006).

### 3.2. Detour test

Forty out of 90 chicks left the start area and passed the goal line to reach their companions. The mean time for these chicks to solve the problem was  $236.0 \pm 22.4$  s (mean  $\pm$  S.E.).

### 3.3. Tonic immobility

The average time that the birds remained immobile in the TI test was  $101.8 \pm 10.1$  s ( $n = 88$ ). Mean number of induction attempts was  $1.08 \pm 0.04$ .



### 3.4. Runway test

Mean results for all the birds in the runway were: time to leave the start box  $55.7 \pm 11.4$  s, time to reach the middle  $68.5 \pm 10.2$  s, time to reach goal zone  $77.2 \pm 10.8$  s, time spent within the goal zone  $281.7 \pm 15.7$  s and mean number of entries into the goal zone  $3.87 \pm 0.2$ .

### 3.5. Radial eight armed maze test

Out of the 87 birds that went through the test, 76 of these ate at least one mealworm and 31 hens ate all eight mealworms in an average of  $11.9 \pm 0.7$  min. The mean number of visits to the deeper end of an arm to eat all eight mealworms was  $12.6 \pm 0.8$  (Table 1).

### 3.6. Perch use in layer pens

#### 3.6.1. Daytime scan observations

The most used perches were the 50E and 90E/a perches and the least used one was the 130D perch. The distribution of use of the different perch heights is shown in Fig. 4.

Table 1  
Performance in the radial eight armed maze

Number of mealworms eaten	Number of birds	Number visits	Mean time to eat first mealworm (s)	Mean number of correct choices out of the first eight choices
0	11	2.3	N/A	N/A
1	4	1.5	337	N/A
2	7	2.6	297	N/A
3	2	3.5	675	N/A
4	4	5.5	180	N/A
5	7	9.0	236	4.8 ( $n = 4$ )
6	7	12.9	53	6.3 ( $n = 6$ )
7	14	14.1	125	6.1 ( $n = 14$ )
8	31	12.6	95	6.5 ( $n = 31$ )

N/A: indicates that a mean value was not applicable. Either birds had not eaten any mealworms or less than eight choices had been made.

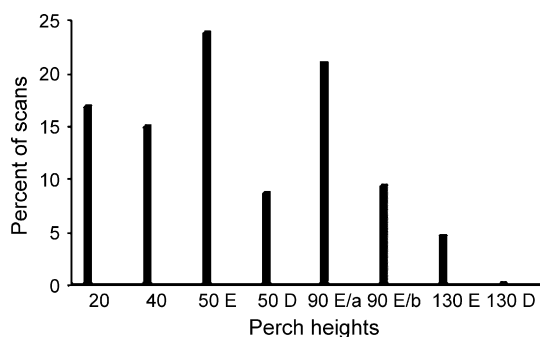

Fig. 4. Distribution of use of the different perch heights from the daytime scan observations given as percentage of scans for all birds and all daytime scans.

There was variation between the birds in how much and how high they perched. On average individual birds were seen perching during the daytime in  $27.1 \pm 2.0\%$  of the scans (range 4.3–79.9%). Most birds (81.6%) were seen to perch at least as high as 90 cm, but only 27.6% were observed on the highest (130 cm) perch during the daytime.

There was a significant pen/group effect on how much the birds used the perches (Kruskal–Wallis,  $H = 14.68$ , d.f. = 4,  $P = 0.005$ ).

### 3.6.2. Daytime continuous observations

The proportion of jumps performed between the different perch combinations is shown in Fig. 1. Out of 15 different possible jumps upward, only four were never observed to be used: 0–90, 20–90, 20–130 and 40–130 and therefore not included in further analyses. The mean number of different perch combinations used by the birds was  $4.3 \pm 0.2$  (mean  $\pm$  S.E.). The bird that was observed to be most variable in how it moved between perches used nine perch combinations whereas the bird showing least variability was never seen to jump between different levels in the system.

### 3.6.3. Night time observations

Almost all hens roosted on a perch during the night and from nights 7 to 10, no hen spent the night on the floor (Fig. 5). The trend was for decreased perching on the lowest (20 cm) perch and increased perching on the 90 and the 130 cm perch. This preference to roost on the two highest perches was most noticeable from night 6 onwards, which coincided with the change to use a period of dim light before complete darkness. The difference in mean perching height during nights 2–5 and 6–10, and even between nights 5 and 6, was highly significant (Mann–Whitney,  $W = 5884$ ,  $P < 0.001$ ).

### 3.7. Relationships between detour, radial maze, runway and TI test and perching behaviour

A Principal Component Analysis was carried out on the Spearman correlation matrix in order to investigate the relationship between how the chicks performed in the different tests and their perching behaviour. The analysis is based on 84 observations and 11 variables. The number of variables used from the different tests varied. There was one from the detour test (detour time), one from the radial maze (RM number of visits into different arms) two from the runway test (RW time to reach goal zone and RW time spent in goal zone), one from the tonic immobility test (TI time), two from the perching observations in the rearing pens (first day to perch and percentage perching weeks 1–6) and four variables from the perching observations in the layer pens (LP number of used combinations, LP highest perch, LP number of scans on a perch first 2 h of observations and LP total number of scans on a perch minus the first 2 h of observations).

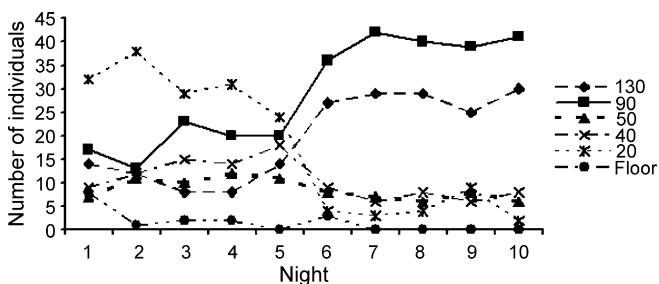

Fig. 5. Number of individuals night perching on the different perch heights.

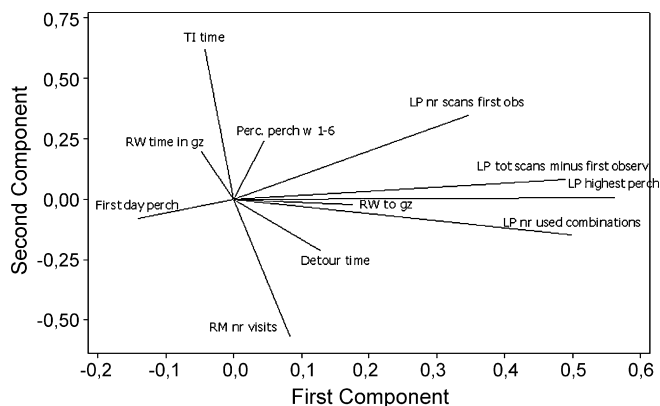

Fig. 6. Loading plot from a Principal Component Analysis using 11 variables with 84 observations each. Tests and variables included are: detour test (detour time), radial maze (RM number of visits into different arms), runway test (RW time to reach goal zone and RW time spent in goal zone), tonic immobility test (TI time) and perching observations from rearing (first day to perch and percentage perching weeks 1–6) and layer pens (LP number of used combinations, LP highest perch, LP number of scans on a perch first 2 h of observations and LP total number of scans on a perch minus the first 2 h of observations).

Overall the explanation of how the variables related to each other was relatively low in this PCA, with 54% of the variation in the data explained by the first four components. The variance explained by the first component was 18.1% and the variance explained by the second component was 12.9%. When interpreting the loading plot (Fig. 6) three of the variables from the laying pen (LP) (highest perch, number of used combinations, total number of scans minus first observation) were plotted in the same area close to the border of the plot and thus contributed most information in the model (variables which have a small contribution to the PCA were plotted near the centre of the loading plot). This indicated that these three variables were correlated and so a bird which perched high up also perched often and jumped between several different perch heights in the laying pen. Although some caution in this interpretation is needed since there was a pen effect on the amount of perching performed in the pens (see Section 3.6.1). The fourth variable measured in the laying pen “LP number of scans first observation” differed slightly from the other three, although it is in the same quadrant of the plot. Interestingly, the variable “first day to perch” was plotted in the opposite direction, implying that the earlier the chicks started to perch, the better they were at perching as pullets in the laying pen. However, the loading for when chicks started to perch was weak. The variables “TI time” and “RM number visits” were plotted in opposite directions to each other at the border of the plot, indicating that birds with a longer duration of tonic immobility visited fewer arms in the maze. The almost 90° angle between these two variables and the four variables from the laying pen shows that even if these six variables contribute most to the explanation of the data there seems to be no relationship between these two groups of variables. There was no indication that a chick’s behaviour in the detour test and its early perching behaviour were correlated. Neither does the runway test seem to be related to behaviour in any of the other tests nor how birds perched. Thus in summary, from this PCA no strong relationship between the performance of the chicks in the different tests and their perching behaviour was found and the only major relationship was between the TI test and how many arms the pullets visited in the radial maze.

Since many individuals did not complete the radial maze task which resulted in missing values for the variables “RM number of correct choice out of first eight choices” and “RM number of

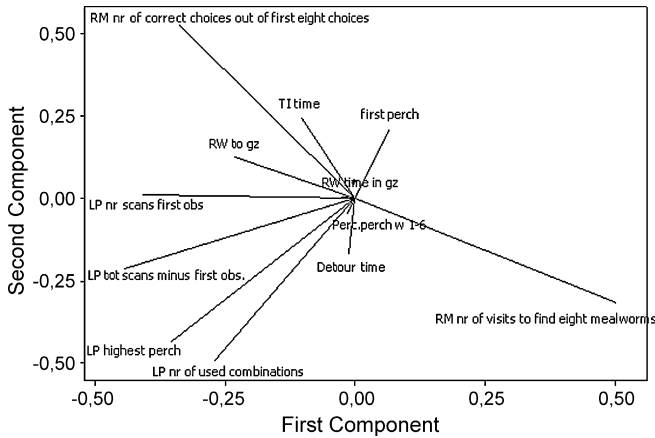

Fig. 7. Loading plot from a Principal Component Analysis using 12 variables with different numbers of observations. Tests and variables included are the same as in Fig. 6 with the exception that for the radial maze the variables used are RM number of correct choice out of first eight choices and RM number of visits needed for finding all mealworms.

visits needed for finding all mealworms” these variables were excluded from the first PCA. In order to investigate them an additional PCA was carried out with these two variables included instead of the previously used variable from the radial maze, “RM number of visits”. This second PCA was based on the Spearman correlation for each pair of variables, and therefore on different numbers of observations. The loading plot of this analysis was similar to the loading plot in the first analysis, but with the additional information that the two variables “RM number of correct choice out of first eight choices” and “RM number of visits needed for finding all maggots” seemed to explain a large part of the variation in this analysis (Fig. 7). Their loadings were plotted in opposite directions indicating that with more correct choices out of the first eight choices, fewer visits into the arms were needed to find all eight maggots. In addition the variable “LP number of scans first observation” was plotted fairly close to the two variables measured in the radial maze, indicating a relationship between how much the pullets used the perches when first released in the layer pen with how well they oriented in their search for the mealworms in the radial maze.

#### 4. Discussion

In this study there were indications that perching behaviour (a three-dimensional skill) was related to spatial skill in a two-dimensional task (in this case a radial maze test), which was the main question in this study. This relationship between three and two-dimensional spatial skills was seen when the birds were first placed in the new perching environment, implying that the novelty of the environment was an important criterion. As birds became familiar with the complex perching environment differences in spatial skill seemed less important in determining how they moved around and used the perches. Unfortunately our results could shed no light on our two subsequent questions, which were whether a chick starts to perch early because it is hatched with a good spatial ability or whether spatial ability develops mainly through an early and frequent use of perches, i.e. whether spatial ability is innate or acquired. Several possible explanations for the findings in this study are explored in this discussion and ideas for future

studies to investigate the development of spatial ability and the implications of these results for rearing of chicks commercially are also presented.

Since all but one chick were seen on a perch during their first 6 weeks of life, one argument for the results might be that there was too little variation between the chicks in their perching ability. This is unlikely though since the later observations, in the complex environment of the layer pen, demonstrated differences between birds. We feel a more likely explanation is that since the perches in the rearing pens were rather low, they might not have proposed a difficult enough challenge for the chicks. Besides the fact that almost all chicks learnt to perch, the variation around the average age at which chicks started to use them was moderate, whereas there was a large variation between chicks in time taken to solve the detour test and half of them never solved it in the time available. It would be interesting to repeat the study with a more difficult first perching environment to see if this resulted in a significant relationship between innate spatial skill and the age at which a chick learns to perch. The practical interpretation of this result though is that given easy access to perches, most chicks will learn to use them without assistance.

The fact that only perch use in the first hours of access to the complex laying pen system seemed to be related to skills in the radial maze supports the argument that it is only when the perching test is challenging that differences in perching skill can be detected. Once the birds became more familiar with the layer pen, then any effect of better spatial skill was no longer apparent. The suggestion that differences in spatial skills are only apparent in complex tasks has been shown in humans by [Wanzel et al. \(2003\)](#). They showed that good visual-spatial ability was associated with performance in a spatially complex surgical procedure initially, but that experienced people doing the same surgical procedure did not score higher on the visual-spatial task. This result suggests that practice overcomes the differences. In a study by [Gunnarsson et al. \(2000\)](#) pullets which had been reared with access to perches from day 1 or from 8 weeks of age showed no obvious difference in perch use at 16 weeks of age in their home pens after the birds reared without perches had been trained to start using the perches. But in a more complex new test situation, pullets with early access to perches showed a more flexible use of the three-dimensional space, which the authors interpreted as these birds having developed a better cognitive spatial ability. These results may imply that even if birds have had inappropriate rearing they can learn with practice to function in complex systems, but they may never be able to develop the same flexibility in the use of the aviary as birds reared with perches. It would be interesting to investigate this by comparing routes taken by hens living in the same aviary but reared under different circumstances. Our results would support the hypothesis that the earlier the birds start to perch, the better they utilize the perches provided in the new environment (i.e. greater flexibility in number of used perch combinations). A consequence of this may be problems for the ones reared without perches, or given them later during rearing, in getting access to resources if for some reason their usual routes are blocked, i.e. by the presence of a higher ranking individual.

It was a necessary part of this study to use spatial tests that were restricted to solving problems in two dimensions and therefore independent of any differences in bird physical abilities related to differential perch use. In addition, since we were interested in how well the birds solved a spatial problem, and not their capability to learn, each test in our study could only be used once. The two tests of spatial ability, the detour test and the radial maze, were chosen because they are standard tests in this area. The detour test has been used extensively to measure spatial ability in young chicks ([Regolin et al., 1994, 1995a, 1995b](#); [Freire et al., 2004](#)). That there was no indication in this study that the results of the chicks in the detour test was related to the start or frequency of perching in our chicks supports [Appleby and Duncan's \(1989\)](#) suggestion that whereas initiation of perching involves learning, variation in amount of perching once it is

learned is probably due to motivational differences between individuals. The second spatial test, the radial maze is also a well-used test to measure spatial ability (see Lipp et al., 2001 for a review). Although with hindsight one could question whether this test is fully appropriate for a species adapted to a patchy distribution of food in space and time, it has been used previously in an egg laying strain (Zimmerman et al., 2003). Although both testing two-dimensional skills, the two tests do not present the same type of problem. This, plus the fact that we tested the birds at very different ages, may account for the lack of correlation between them. We are not sure how this could be explored in future studies without developing and validating new tests of spatial ability. On the other hand, it could also imply that the radial maze test is the most appropriate two-dimensional test for estimating skill in three dimensions in poultry. All these factors are confounded in this study since it was not our aim to develop spatial tests. We discuss them here as a contribution to researchers in the future working in this area.

Other factors that are known to play a large role on performance in a wide range of tests are fearfulness and sociality and for this reason we investigated fearfulness, as estimated by a test of tonic immobility, and sociality, as estimated by measures in a runway test, to control for bird test results in the detour and radial maze spatial tests. Results in the TI and runway tests could not explain the results in the detour test, but to some extent a pullet's performance in the radial maze was affected by its fearfulness. Our results suggest that fear inhibited exploration in the radial maze test arena and those pullets that actively searched for the mealworms in the radial maze were less fearful than the ones that did not, supporting the findings of Regolin et al. (1995b).

In conclusion, considering that aviary housing systems for poultry are becoming more frequent, we argue that there is an increasing need to understanding how spatial skills are acquired by birds (in the absence of a mother hen) and the interaction between acquired and innate spatial skills. This is so we can design appropriate rearing environments that maximise the chances of pullets coming into the laying house with the necessary skills to adapt and cope easily. One step towards this may be further development of spatial tests for poultry.

## Acknowledgements

Sincere thanks to Alf Blomqvist for taking care of the birds and to Anne Larsen and Linda Björklund who helped with collecting data. Thanks to Jan-Eric Englund for statistical advice. This work was funded by The Swedish Research Council for Environment, Agricultural Sciences and Spatial Planning and was part of a larger collaborative project for the Nordic Joint Committee for Agricultural Research called "Modification of rearing conditions to improve welfare of layers: Basic and applied ethological studies".

## References

- Appleby, M.C., Duncan, I.J.H., McRae, H.E., 1988. Perching and floor laying by domestic hens: experimental results and their commercial application. *Br. Poult. Sci.* 29, 351–357.
- Appleby, M.C., Duncan, I.J.H., 1989. Development of perching in hens. *Biol. Behav.* 14, 157–168.
- Brake, J., Keeley, T.P., Jones, R.B., 1994. Effect of age and presence of perches during rearing on tonic immobility fear reactions of broiler breeder pullets. *Poult. Sci.* 73, 1470–1474.
- Cordiner, L.S., Savory, C.J., 2001. Use of perches and nestboxes by laying hens in relation to social status, based on examination of consistency of ranking orders and frequency of interaction. *Appl. Anim. Behav. Sci.* 71, 305–317.
- Freire, R., Cheng, H.-W., Nicol, C.J., 2004. Development of spatial memory in occlusion-experienced domestic chicks. *Anim. Behav.* 67, 141–150.

- Gunnarsson, S., Keeling, L.J., Svedberg, J., 1999. Effect of rearing factors on the prevalence of floor eggs, cloacal cannibalism and feather pecking in commercial flocks of loose housed laying hens. *Br. Poult. Sci.* 40, 12–18.
- Gunnarsson, S., Yngvesson, J., Keeling, L.J., Forkman, B., 2000. Rearing without early access to perches impairs the spatial skills of laying hens. *Appl. Anim. Behav. Sci.* 67, 217–228.
- Healy, S.D., Clayton, N.S., Krebs, J.R., 1994. Development of hippocampal specialisation in two species of tit (*Parus* spp.). *Behav. Brain Res.* 61, 23–28.
- Heikkilä, M., Wichman, A., Gunnarsson, S., Keeling, L.J., Valros, A., 2006. Development of perching behaviour in chicks—role of environmental enrichment. *Appl. Anim. Behav. Sci.* 99, 145–156.
- Jones, R.B., Marin, R.H., Garcia, D.A., Arce, A., 1999. T-maze behaviour in domestic chicks: a search for underlying variables. *Anim. Behav.* 58, 211–217.
- Kamil, A.C., Balda, R.P., Olson, D.J., 1994. Performance of four seed-caching corvid species in the radial-arm maze analog. *J. Comp. Psychol.* 108, 385–393.
- Keeling, L.J., 1997. A comparison of two basic characteristics of a perch for laying hens. In: *Proceedings of the 31st International Congress of the International Society of Applied Ethology, Prague, August 13–16, 1997*, p. 83.
- Lipp, H.-P., Pleskacheva, M.G., Gossweiler, H., Ricceri, L., Smirnova, A.A., Garin, N.N., Perepiolkina, O.P., Voronkov, D.N., Kuptsov, P.A., Dell’Omo, G., 2001. A large outdoor radial maze for comparative studies in birds and mammals. *Neurosci. Biobehav. Rev.* 25, 83–99.
- Olsson, I.A.S., Keeling, L.J., 2000. Night-time roosting in laying hens and the effect of thwarting access to perches. *Appl. Anim. Behav. Sci.* 68, 243–256.
- Olsson, I.A.S., Keeling, L.J., 2002. The push-door for measuring motivation in hens: laying hens are motivated to perch at night. *Anim. Welf.* 11 (1), 11–19.
- Regolin, L., Vallortigara, G., Zanforlin, M., 1994. Perceptual and motivational aspects of detour behaviour in young chicks. *Anim. Behav.* 47, 123–131.
- Regolin, L., Vallortigara, G., Zanforlin, M., 1995a. Object and spatial representations in detour problems by chicks. *Anim. Behav.* 49, 195–199.
- Regolin, L., Vallortigara, G., Zanforlin, M., 1995b. Detour behaviour in the domestic chick: searching for a disappearing prey or a disappearing social partner. *Anim. Behav.* 50, 203–211.
- Rogers, L.J., 1995. *The Development of Brain and Behaviour in the Chicken*. CAB International, Wallingford, UK, p. 5.
- Sherry, D., Healy, S., 1998. Neural mechanisms of spatial representation. In: Healy, S. (Ed.), *Spatial Representation in Animals*. Oxford University Press, Oxford, pp. 133–157.
- Scholes, N.W., Wheaton, L.G., 1966. Critical period for detour learning in developing chicks. *Life Sci.* 5, 1859–1865.
- Wanzel, K.R., Hamstra, S.J., Caminiti, M.F., Anastakis, D.J., Grober, E.D., Reznick, R.K., 2003. Visual-spatial ability correlates with efficiency of hand motion and successful surgical performance. *Surgery* 134, 750–757.
- Wilkie, D.M., Spetch, M.L., Chew, L., 1981. The ring dove’s short-term memory capacity for spatial information. *Anim. Behav.* 29, 639–641.
- Workman, L., Andrew, R.J., 1989. Simultaneous changes in behaviour and in lateralization during the development of male and female domestic chicks. *Anim. Behav.* 38, 596–605.
- Yngvesson, J., 2002. *Cannibalism in laying hens: characteristics of individual hens and effects of perches during rearing*. Doctoral thesis. Swedish University of Agricultural Sciences, Acta Universitatis Agriculturae Sueciae Veterinaria, p. 120.
- Zimmerman, P.H., Pope, S.J., Guilford, T., Nicol, C.J., 2003. Navigational ability in the domestic fowl (*Gallus gallus domesticus*). *Appl. Anim. Behav. Sci.* 80, 327–336.